



Coaling tower by Don Taschner, MMR
See inside for more photos of model contest winners



Winter 2011: Volume 18, Number 4

The RPO is the official publication of the Gateway Division of the National Model Railroad Association

Editor: Mike Thomas

Cover Photo: Richard Schumacher

Articles, photos and any other materials for publication are to be sent to the Editor. No payment can be made for publication of any materials. Regular issues are published quarterly: Spring, Summer, Fall, and Winter. Subscriptions to the RPO are available to members of the NMRA as a service provided by members of the Gateway Division. Send subscription applications and renewals to the Division Treasurer.

Any item may be reproduced by other NMRA publications, unless specifically restricted, as long as author and source credit is included. Advertising of interest to our membership is accepted for publication in the RPO. Contact the Editor or Treasurer for current rates and artwork size information. Please send submissions, suggestions, letters, and address corrections to:

Editor, The RPO
Gateway Division NMRA
3900 Shenandoah Avenue
Saint Louis, MO 63110-4016

Articles may be submitted as handwritten, typed, plain unformatted text on disk, or plain text via email to mathomasATspeakeasy.net; photo submissions may be made as hi-res digital files, 35mm slides or negatives or as prints.

All content is Copyright © 2011 Gateway Division NMRA unless otherwise noted.

Visit our website at www.gatewaynmra.org

In This Issue

Joint Gateway / NRHS Picnic3
Layout Design Meet in Tulsa4
Fall Meet Model Contest Winners5
Redboard Salutes Dee Joseph.....8
Building the BC&G Railbus.....10
Achievement Program13
Dave Roeder's WG&F14
Kalmbach Library Photo Scanning ...16
Director's Report.....17
Meeting Minutes20

Superintendent's Desk

by Hank Kraichely

Well we are now at the beginning for a new year and it looks like it will be a good one. Recently the officers met to develop a plan for the coming year the details follow.

The monthly clinics will include: MMRs sharing various building techniques in Jan and Feb. In March Brian Post will show how to program DCC decoders to take advantage of their capabilities; Rich Lake will discuss operations; in May members will receive their AMB structure; June we will visit the K-10 layout; we will have a swap meet in July; Learn to paint backdrops in August; in September we will see the member's handy-work and award prizes to the winners; October will feature making castings and custom decals; November will see our annual Holiday party and finally in December we will have our first Bring and Brag (bring your model and describe how you constructed it. (The schedule is tentative beyond the 2nd quarter.)

2011 will again see a number of fun outside activities including a layout tour in late March, the annual picnic, two

weekend operations sessions plus some type of prototype tour.

I think you will agree with me that 2011 will be a exciting year so why not decide right now to attend some or all the Division meetings and take part in one or more of the outside activities. Many people are working to make Gateway Division one of the best.

- Hank

Annual Joint Picnic

by Ron Gawedzinski

On Saturday, September 25, 2010, the Gateway Division NMRA and the St. Louis Chapter NRHS held the 3rd get-together picnic of two fine train groups at the Wabash, Frisco, and Pacific Railroad, Glencoe, Missouri. The WF&P RR runs 12-inch gauge small-scale steam and diesel trains alongside the Meramec River. It provides a two mile roundtrip ride.

The weather was great, the steam and diesel locomotive rides were many, the food, drinks and snow cones were plentiful and the scenery along the Meramec River was beautiful. Some new train friends were made. But most of all people had fun.

This year there were in attendance 105 registered members, families and guests from both groups, along with an additional 17 crew members from the WF&P RR.

The WF&P RR provided several steam and diesel locomotives. There were train rides all day. The WF&P crew were very gracious hosts and they enjoyed having us there as much as we enjoyed their facilities.

This year there were 30 volunteer workers who were exemplary in performing the many tasks at hand: Mary and Bill Birdsell, Phil, Kathryn,

and Matthew Bonzon, Don Bowling, Ron Gawedzinski, Phil Hellwege, Hank Kraichely, Ron Kraus, Noah Lee, Dave Lyon, Bill Miksicek, Jean Myers, David Newell, Joe Obernuefemann, Jan and Bill Schaberg, Rich Schumacher, Andy Sisk, Neva and Rick Sprung, Lynne and John Stoecker, John Stork, Brenda and Tim Stout, Eileen and Al Weber, and Dick Wegner. (If I left your name off please let me know so that I can correct my error. - Ron)

Special thanks go to Bud Anderson and Alex Ford for providing free snow cones to the people at the picnic. Many fine compliments were made about the cool, refreshing and tasty snow cones that were provided. Each year Bud and Alex have brought their equipment, the ice and the many tasty flavors as well as donating their time to the event.

Many members of both groups donated a large number of attendance prizes this year, so just about everyone got a chance to win something.

The Officers of the Gateway Division NMRA and the St. Louis Chapter NRHS thank the members, families and guests for their attendance, their help and their donations that made this picnic a great success. Ron especially wants to thank the above named volunteers, for without them this event could not have been held.

Finally, many thanks to the WF&P crew for making this a success:

WF&P RR - Dale Bitsch, Clayton Cullen, Hunter Debellis, Brad George, Jim Greathouse, Mike Lorange, Karin and Jack Mayhew, Wayne Mosbacher, Dave Neubauer, Rich Owings, Jim Scott, Jimmy Scott, Andrew Wapelhorst, Betty Wapelhorst, Greg Wapelhorst, and Tom White.

Thanks for coming! Ron

Layout Design and Operations in Tulsa

by Dave Salamon

The Indian Nations Division of the NMRA located in Tulsa, OK is pleased to announce that we will be hosting our 2nd Layout Design and Operations Weekend, March 18-20, 2011.

We have 4 presenters lined up with 6 presentations to be given; Tony Koester is going to give two presentations. Doug Gurin will also give two presentations, and Riley Triggs and Keith Robertson are each going to give one. Everyone will be able to attend all six presentations. Updated information on the presenters and presentations will be added to the web page (see below).

The cost is only \$25.00. You can also pre-purchase your lunch, this year we will do a build your own sandwich bar with all the fixings for a mere \$8.00. This will give you an opportunity to talk with the presenters, other participants and old friends while having lunch and not have to get in your car and spend time driving around. We will be doing shirts again, this year we will be doing a polo type shirt, we still haven't decided on the color of shirt, but as soon as we get that nailed down we will add that info to the web page. The logo will be in multiple colors this year too, depends on the final shirt color on the colors that will be used. The shirts are \$25.00, and for 2XL and larger are \$27.00. All these can be done using PayPal on line from the web page or print off a registration form and mail it in.

If you'd like to operate there is that option. We can send you a preference sheet to operate (this doesn't cost, its part of the meet) when you register. To engage more individuals in operation this year we will not have a dedicated open house night, even though if you aren't interested in operating you can still visit the layouts when they are operating if you'd like. There will be three different sessions (Friday night, Saturday night and Sunday morning) and there will be multiple layouts available for each session. Assignment will be done first come and first serve; preference sheets will be emailed later to you after you register.

If you like designing track plans or would like to design a track plan we are hosting a track plan challenge. This isn't a contest; there are no individual winners, as everyone wins on this as we can see how different people would approach the same area and what they would do. These ideas might be of use to your own layout or something to consider in designing and building a layout in the future. On the web site there is a PDF document with some "givens and druthers" and also footprint and elevation drawings with obstacles in the room and everything you need to know about it. I hope that several of you will give this a try.

The layout design challenge entries will be compiled and the author of each one will be given a little time to make a short presentation on their design. If we were to get more entries than time allows for reviewing all of them (This would be a great thing to have!) the committee will go through and select a handful to be presented to everyone. All others will be presented in paper form with a write up about it so that everyone that enters something will have it posted for all to review. After the meet all entries will be compiled and submitted to the Layout Design Journal for possible

publication. After each presentation for the layout design challenge the Panel (comprised of the presenters) will provide comments and feedback on the designs. We will end the meet portion with an open discussion with the panel of presenters with a question and answer session. This was really great last year and we are allowing a little more time for that this year.

Link to the web page:

<http://ldopsigmeet.tulsanmra.org/>

I hope you all can attend the meet as the committee has been doing a lot of work to put together a fantastic program for everyone. It will be a great weekend.

Fall Meet Model Contest Winners

photos by Richard Schumacher

Gateway Division NMRA 2010 Annual Model and Photo Contest

NMRA conventions and train show events feature a model and photo contest where entries are displayed to be viewed and enjoyed by other model railroaders and the general public. Any NMRA member may enter models and

photos into these contests.

The 2010 train show was the first to feature both NMRA (merit) judging and popular vote contests. They are displayed as two sections below.

The following are the contest winners from the 2010 Gateway Division annual model and photo contest.

Merit Judging:



**Steam Locomotive, First Place (Score 114) & Best of Show (tie)
Phil Bonzon, MMR**

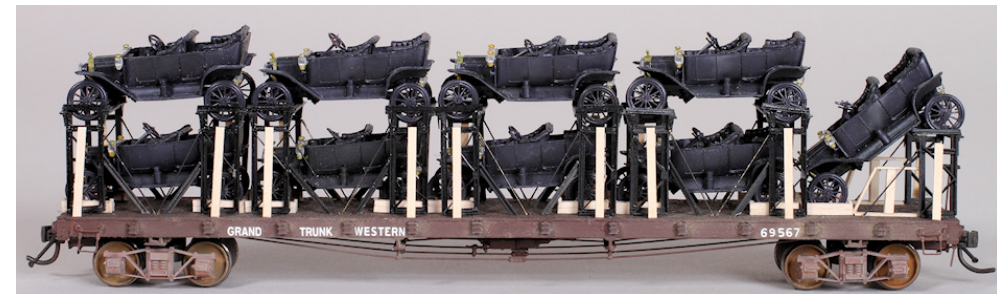

**Freight Car, First Place (Score 114) & Best of Show (tie)
Gregor Moe**



**Non-Freight Cars, First Place (Score 106)
George Spriggs
(also Maintenance-of-Way First Place in popular vote)**



**Diesel Locomotive, First Place
Dave Roeder, MMR**



**Structures, First Place (Score 96)
Gregor Moe**

(also Offline Structures First Place in popular vote)

Popular Vote:



**Steam Locomotive, First Place
Phil Bonzon, MMR**



**Freight Car, First Place
Dave Roeder, MMR**



**Caboose, First Place
Steve Hemmel**

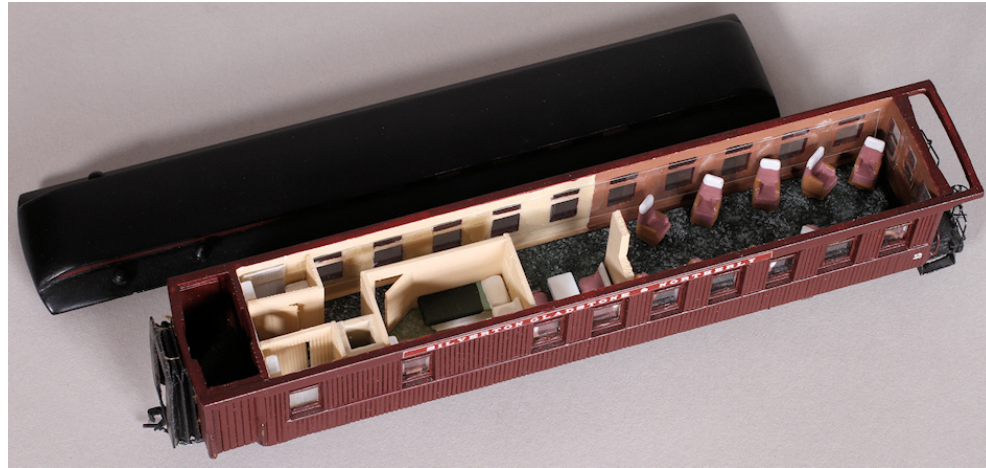

**Passenger Car, First Place
Dave Roeder, MMR**

See cover photo of Online Structures, First Place coaling tower by Don Taschner, MMR



**Whole Train, First Place
Dave Roeder, MMR**

Full size, full color versions of these photos, along with photos of the second and third place model contest winners and the photo contest winners, are posted on the Gateway Division website.

Dee Joseph Tribute

photos by Richard Schumacher

Paul Fries' HO scale model railroad is displayed in the front window of his hobby shop, Red Board Hobbies (2331C Collinsville Rd., Belleville, IL 62221, 618-233-3618). The layout features fall scenery and a small town theme. In early 2010 Paul modified the town square area adding a tribute to Dee Joseph, a well-known and respected local modeler and businessman who is no longer with us.



Building the BC & G Railbus

by Phil Bonzon, MMR

The Railbus was a 1921-built Mack Model AC Railbus that the BC&G acquired in 1941 to provide passenger and mail service between Dundon and Widen, WV, just 18.6 miles away. Twice a day it made the round trip between these two towns in the late 50's with Kenneth Brady as the engineer.

Originally built with a 64 hp 4-cylinder engine, the BC&G replaced the Mack motor with a "more modern" Chevrolet engine and opened up the front of the hood, for additional cooling.



photo by Phil Bonzon, MMR

CONSTRUCTION: Styrene sheet is the principle material used in the model construction. Brass was used for some chassis members, body moldings, pilot, fenders, handrails and horn.

The chassis was made from brass channel shapes that are soldered together and then bonded to the .100-styrene floor with CA adhesive.

The hood was carved from a solid block of styrene to the required shape. The louvers were made from .030-styrene quarter round shapes bonded to the hood with plastic solvent adhesive. The hood hinges are .010-styrene.

The body was made from three layers of styrene. The inner layer, which has the individual window sash cut into it, is .010-styrene; the middle layer, which has the paired windows and doors cut into it, is .030-styrene; and the overlays, which includes the embossed rivets, is .010-styrene. The horizontal and vertical window muntins are scale 1" x 2" styrene strips. All of the styrene was bonded together with plastic solvent adhesive. The molding above and below the windows was made from .020-brass rod bonded to the body with CA adhesive. The rivets were hand embossed using a NMSL rivet tool.

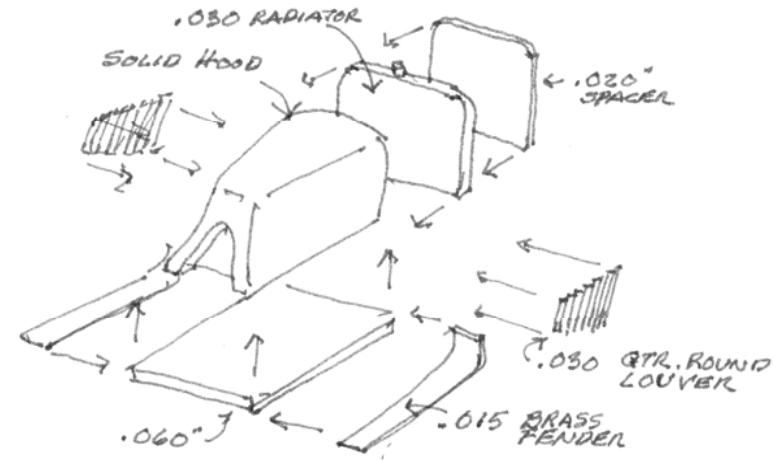

Hood construction

The roof was made from a layer of .090-styrene bonded to an interior layer of .030-styrene. Lead weights were adhered to the underside of the roof to increase the weight for better electrical pickup. The canvas covering was simulated by applying a single layer of facial tissue to the roof that is coated with 'Grimy Black' enamel and then given an overcoat of the same enamel. The roof is removable to allow access to the interior and is retained by a screw from the underside of the chassis.

The front fenders were made from .015-brass sheet cut and formed to shape and then bonded to the body with CA adhesive. The pilot was made from brass angles with holes drilled to locate the brass rods; the assembly was soldered together; the projecting ends filed off and pilot was bonded to the body with CA adhesive.

The handrails, grab irons and door handles were formed from .010-brass wire and applied to the body with CA adhesive.

Glazing was made from "overhead projector" film and bonded to the body, after painting and weathering, with CA adhesive.

Front and rear headlights were made from aluminum tubes with 14-volt light bulbs wired to the decoder to provide directional lighting. The nonfunctioning headlights were made from styrene rod and brass wire.

The front steps were made from styrene while the rear was made from brass wire.

The grille was made from .010-brass wire soldered together.

The motor/gear unit is a NWSL "Flea III" assembly, supplied by custom order, with 36" nine spoke wheels. It is built into a styrene subassembly that includes the brakes, simulated

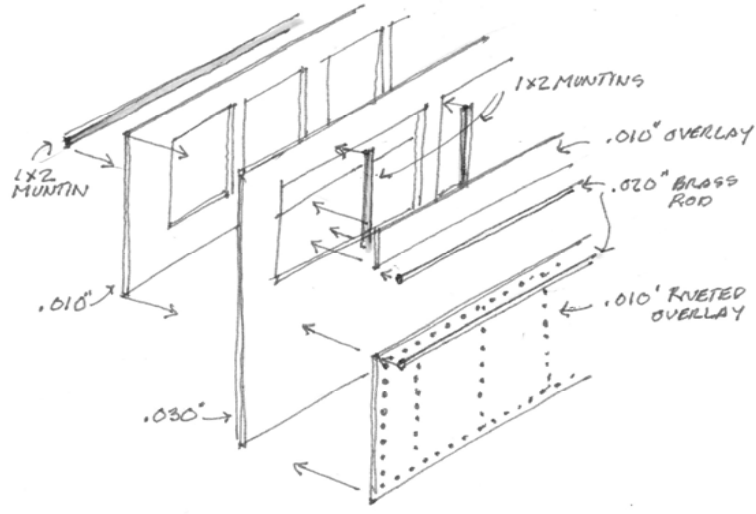

Car side construction

leaf springs and supports, brass sand pipes, simulated drive staff and continuation of the brass chassis channels in styrene. The motor was hard-wired for DCC. The sub assembly fastens into the body assembly with two brass screws.

A LokSound's decoder and sound system was hard-wired into the model to replicate the sounds of the Railbus.

The front truck was made to resemble the BC&G prototype from styrene sections that were bonded together with plastic solvent adhesive. The three major components, truck sides and cross member, were fastened together using brass pins and CA adhesive. The 26" NWSL wheels provide electrical power pickup through .008-phosphorus bronze 'wiper' wires to the decoder. Simulated brake shoes and journal boxes were made from styrene.

Interior: An interior was made for the passenger compartment from styrene with a raised floor, to clear the decoder and speaker located below. Lead sheet was bonded to the underside of the raised floor for additional weight. Because of the raised floor, the bench seats had to be abbreviated, as did the five passenger figures, plus the engineer and a coal stove. In the baggage compartment, wood crates made from scale lumber, cover the motor.

Exterior: There are many details included on the exterior; the brass horn, the roof ventilators and the brass radiator cap, the headlights on the pilot (all turned using a Dremel tool and a file as a lathe); the grille; the battery box located on the left front fender; the square gas tanks with their filler spouts; the underbody storage shelves; the smoke stack; and all the details at the rear axle, i.e., springs, brakes and sanding pipes, just like the BC&G prototype.

FINISH: The model is finished in Floquil's enamels in colors corresponding to the BC&G prototype for the period. Custom-made decals were applied and the model was given a light weathering using

Floquil's 'mud' and 'dust' and a light wash of India ink.

SCRATCHBUILT: The model is entirely scratchbuilt except for the following allowable items: motor/gear unit, wheels, light bulbs, DCC decoder, and sound system.

Gregor & Bonnie Moe Earn AP Certificates

photos by Phil Bonzon, MMR

At our January meeting Don Taschner, MMR, and Dave Roeder, MMR gave presentations on how they went about qualifying for some of the AP certificates they've earned and encouraged the membership to join them in the program. Appropriately enough, Don, who is Gateway Division Achievement Program co-chair, then presented AP merit award certificates to both Bonnie and Gregor Moe in the Cars category, and also presented Gregor with his Achievement Certificate for Model Railroad Engineer – Electrical. Congratulations to both!



Dave Roeder's Webster Groves & Fenton

photos by Dave Roeder, MMR



When an editor needs to fill a couple of blank pages before sending the RPO to the printer, it's hard to beat Dave Roeder's modeling. His double-deck HO layout keeps a crew of seven to nine busy during monthly operating sessions. The WG&F is a fictitious industrial shortline with Burlington Northern connections serving industries in Valley Park and nearby areas of Saint Louis County.

Kalmbach Library Photo Scanning

by Gerry Leone, MMR
NMRA Communications Director

If you're a subscriber to NMRA Magazine (formerly Scale Rails) you've seen the "Timeframes" series of photographs printed on the magazine's last page. Those are all shots taken from the Kalmbach Memorial Library (KML) archives. The fact is, our NMRA Library has over 100,000 images, negatives, slides, plans and drawings, and only a handful have ever been seen by NMRA members because it would have entailed making a personal trip to Headquarters in Chattanooga, Tennessee, to flip through the files. Soon that will all change, thanks to the NMRA's Diamond Club. The Diamond Club is a fundraiser specifically designed to support adding enhanced content to our website at www.nmra.org. The first item on the list of is scanning those 100,000 images and making them available for download.



The good news is that scanning of the photographs has begun! In August of 2010, Historical Archives Services (HAS), the firm the NMRA Board of Directors hired to do the scans and design the photo website, began receiving and cataloging

shipments of photographs from KML. HAS estimates that the first batch of photographs will be available for viewing online sometime in the first quarter of 2011, after a short period of beta testing late this year. Putting the entire library online will be a costly, time consuming task, since each photo's listing will also contain highly detailed, searchable metadata,



which is being added by the railroad experts at HAS. This detailed metadata will make it easier and faster for users to find exactly the photograph they're looking for. Current plans are to make the low-resolution thumbnails of the photographs available to everyone via the website around the clock. Users will be able to download high-resolution files, and NMRA members will receive a substantial discount. Proceeds from the scans will help fund the remainder of the project and future Diamond Club web projects. As promising as this sounds, it's important to remember that the Diamond Club still hasn't reached its projected goal of \$75,000. If you haven't contributed to this worthy cause, please send your donation now to The Diamond Club, NMRA, 4121 Cromwell Road, Chattanooga, TN 376421, or do it online at www.nmra.org/diamondclub.

Director's Report

by Phil Bonzon, MMR

MCoR BOD Meeting January 22, 2011

I. General Comments:

The Gateway Division continues to meet monthly on a rotating basis between the VFW Hall in O'Fallon, IL and Trinity Church in Chesterfield, MO. The average monthly attendance continues at 20 to 40 plus. The Missouri meetings have the better attendance, but we have seen a slightly improved attendance at our meetings held in O'Fallon, IL. Meeting announcements are communicated by postcard to members who are current with their annual \$5 subscription fees or via e-mail to members who prefer this method of communication. Meeting information is also posted on the Gateway Division website, which is www.gatewaynmra.org. Meeting and website updates are available through our RSS feed at

<http://feeds.gatewaynmra.org/GatewayNMRA>.

II. Division Monthly Meetings/Clinics:

July through December 2010:

July (MO): Second clinic on prototypical operations with Gene Coffman presenting the use of the "Rail OP's" computer program and John Schindler presenting a summary on operations.

August (IL): "Custom building turnouts" presented by Larry Wodell

September (MO): "Members who received a American Model Builder's "Company House" building kit at the May meeting brought their completed models for a "show and tell" presentation/contest and winners were selected by John Heitzman, President of AMB – Gift Certificates for a local hobby shop were given as prizes. First Place, Phil Bonzon; Second Place, Dick Wegner and Third Place, Gregor Moe

October (IL): "Adjusting DCC Decoder CVs to Speed Match Engines" was to be presented by Brian Post, but last minute work problem caused the clinic to be canceled and has been rescheduled for March 2011.

November (MO): "Annual Gateway Division Holiday Party and Pot-Luck Dinner. Bill Linson gave a presentation on his Rail Fan trip to the Pennsy Horseshoe Curve.

December (IL): Using the Gateway Division's switching layout, a timed "Switching Contest"

was held. Two person teams were given a switch list and eight minutes to complete operations. Gift Certificates for a local hobby shop were given as prizes. First Place Team, Bill Linson & Jimmy Ables, Second Place Team, Tim Stout & Larry Wodell, Third Place Team, Hank Kraichely & Don Ayres. Phil Bonzon MMR set-up the contest so was excluded from competing.

IIA. Planned Division Meetings/Clinics:

January through June 2011:

January (MO) and February (IL) 2011 clinics will be "Modeling with the Masters" presented by four MMRs, Don Taschner MMR #403, Dave Roeder MMR #373, Randy Meyer MMR #390 and Phil Bonzon MMR #427.

March, 2011 (MO) clinic will be "Adjusting DCC Decoder CVs to Speed Match Engines" to be presented by Brian Post.

April, 2011 (IL) clinic will be on Operations presented by Rich Lake.

May 2011 (MO) AMB kits will be distributed to members to be constructed for judging in September and a presentation will be made on how to build the model for merit award.

III. 2010 Gateway Fall Meet and Model Contest: November 13 at Trinity Church:

The annual meet was very successful. We had 49 tables, which is an increase from 41 tables in 2009 and they were sold out. Paid attendance was down slightly at 308 from 335 in 2009, but total revenue of \$2,501 was within \$10 of 2009's revenue.

For the Model Contest, this year we added a Merit Judged category and a Display category to the Popular Vote used previously. The change was made to increase the number of awards available and hopefully the number entries and AP participation. There were 21 entries in the Merit Judged category, of which 16 models scored Merit for 2010, whereas it was 7 for 2009, so AP participation increased, which was encouraging, but the total number of entries was 71 for 2010, whereas it was 81 for 2009, which was a little disappointing. This might have been caused by the late decision and announcement to change the contest award rules, so it did not have the intended effect for entries, we will have to see at the 2011 Fall Meet.

John Carty, Rich and Venita Lake, Randy Meyer MMR and Co-AP Chairmen, Don Taschner MMR and Phil Bonzon MMR provided merit Judging.

Six clinics were presented with Dave Roeder giving three, Rich Lake giving one, John Carty giving one and Jack Stroker giving one. Also,

we had layout tours with three layouts open for viewing.

IV. AP Activity:

Golden Spikes awarded to Gene Coffman and Gregor Moe

Scenery AP Certificate: Gregor Moe

Civil Engineer AP Certificate: Gregor Moe

Electrical Engineer AP Certificate: Gregor Moe

Six Car Merit Awards: Gregor Moe

One Structure Merit Award: Gregor Moe

One Car Merit Award: Bonnie Moe

Gregor Moe is on his way to his MMR and we will continue to encourage him.

Other members have expressed an interest and are working on the Achievement Program. We are trying to encourage participation in the Achievement Program through contests, clinics and the appointment of Phil Bonzon MMR and Don Taschner MMR as Co-AP Chairmen.

V. Membership Activity:

Our Division 2010 Membership Campaign, with its "Recruiting Posters" in nine local hobby shops, attendance at Train Shows with our "Switching Layout", our "Rail Op Weekend", and interesting clinics/activities has had some success in obtaining new members, retaining existing members and keeping them active in Division programs. What has been very satisfying is the active participation shown by some of the new members, who have been manning our booth at train shows and participating in our activities; our new Assistant Superintendent, Bill Linson, joined in May 1, 2010.

January 2010 membership data show 208 active Gateway members and the November 2010 membership data show 233 active members for a net gain of 25 (+12%) members. Our YTD gain, as of November 2010 data, in new members and rerailed members is 31(+15%). It appears our campaign is working.

Upon confirmation of membership, the Gateway Membership Chairman mails a welcome letter with a copy of the latest RPO and the Gateway Membership Directory to each new member.

VI. Activities used to promote the hobby and increase membership:

a. Periodic layout tours on specific dates to visit Division member layouts

b. A Joint tour with the local NRHS chapter was organized by Ron Gawedzinski to the Barriger Railroad Library at the Mercantile Library, University of Missouri; St. Louis.

c. Joint picnic with NRHS at the Wabash, Frisco, and Pacific RR in Glencoe, MO

d. Gateway Division participated in five train shows since June 2010 Report with the NMRA

Gateway membership recruiting booth and the Gateway switching layout to promote membership in the NMRA and it has been well received with a lot of membership applications taken, especially the Rail Pass and 31 new members. Also, this has gotten existing members involved in manning the booth and promoting NMRA membership. In 2011 the switching layout will again be displayed at train shows. Some train shows even pay us to display and with others it is free.

e. Membership recruiting posters have been placed in nine local hobby shops.

f. After two months of clinics on prototypical operations, a weekend of prototypical operations, "Gateway Rail Op Weekend", was held September 17 & 18, 2010 with three operating sessions and six layouts available. The "Rail Op" was advertised on the Gateway website, as was its registration. You had to be an NMRA member to participate and thirty-six did that. The weekend was a success and survey taken after "Rail Op" was 100% in favor of having it at least twice a year. Also, a very favorable article, written by Jim Duncan (OPSIG Regional Area Coordinator) was in the January 2011 issue of "The Dispatcher's Office" the OPSIG publication. For 2011 we are planning both a Spring and a Fall "Rail Op Weekend". The Rail Op weekend was organized and chaired by Phil Bonzon MMR, OPSIG member.

VII. RPO:

Mike Thomas continues to do an excellent job as the Editor of the Division quarterly publication entitled the "RPO". A B&W printed copy is sent to those members paying their \$5/yr mailing subscription fee and is available to all, in color, through the Gateway website. Mike is always looking for articles to publish so any MCoR members who might be interested please contact Mike.

VIII. The Gateway Division website:

(www.gatewaynmra.org) managed by Richard Schumacher, continues to be very busy, providing information to members and prospective members.

Web Analytics Report for the GatewayNMRA.org web site for the month of December 2010 Reporting starting in December 2010 is different from the previous reports. A number of changes were made to reflect issues Richard wanted to address in the reporting to ensure only information on actual human visitors is being reported.

The biggest change is that the number of visitors (a lower number than previous reports) now reflects only actual human visitors that looked at web pages. This provides a more

accurate number than most web reports (who like to include inflated statistics).

The more interesting number is pageviews, which is our monthly highest ever (even though this is also a number which has been adjusted down to remove artifacts). The pageview number is also slightly underreported, since it will not include visitors who had JavaScript disabled in their browsers. There are currently 253 active web pages on the gatewaynmra.org site.

General Web Metrics:

24,997 visits (note that this number has been adjusted down to reflect only actual human visitors)

110,105 pageviews (note that this number reflects only visitors to web pages, it does not include pdfs or image-only views)

980 pdf downloads (this only reflects downloads through a link on the gatewaynmra.org website)

3,678,769 hits

37.5 GB bandwidth

About 4.40 pages viewed per visit

Web Traffic:

All traffic sources sent 24,997 visits via 416 sources and mediums

Traffic: 65.98% organic search, 20.92% referrals, 12.92% direct, 0.17% other

Referring sites sent 5,230 visits via 400 sources

Search sent 16,494 total visits via 8,354 keywords and 11 sources

1. Google 12,531

2. Yahoo 1,651

3. Bing 1,317

4. Search 443

5. AOL 333

6. Ask 208

0.14% visits used site search (the "search" button on the pages)

Top Site Content (by Title) 253 page titles were viewed a total of 110,105 times

1. Small HO Scale Model Railroad Layouts with Track Plans | Gateway Central Train Layout 17,051

2. Model Trains and Model Railroads | Gateway Division NMRA {Home page} 4,523

3. 4x8 HO Scale Model Railroad Layout Display at the Missouri Historical Society 3,637

4. Directory of Greater St. Louis Area Model Railroad and Train Layouts | Gateway NMRA 3,478

5. Scale Model Railroad Download Page | Signs, Interiors and Backgrounds | Gateway NMRA 3,056

6. HO Scale Small Switching Model Railroad | Designing the Gateway Central XV 2,951

7. Model Railroad & Model Train Article Library | Tips, Tricks, Photos & Techniques | Gateway NMRA 2,768

8. 2005 Riverport Theme Model Railroad Layout | Gateway Central XII (2005) | Gateway NMRA 2,677

9. Gateway Central X (2003) Small HO Scale Model Railroad Layout with photos and trackplan 2,587

10. 4x8 HO Model Railroad Track Plan | Gateway 2001 National Train Show Model Railroader Magazine Layout 2,417

11. Small HO Scale Model Railroad Layout | Gateway Central IX (2002) Project Train Layout 2,322

12. Digital Command Control for Model Train Layouts 2,202

13. Contest and Award Winning Train Models and Photos | Gateway NMRA 1,974

14. Railroads in the Civil War 1,925

15. Dave Roeder Webster Groves & Fenton HO Scale Model Railroad Layout | Page 1 of 3 1,817

16. Greater St. Louis Area Model Railroad and Train Layouts | Page 3 | K-O | Gateway NMRA 1,801

17. 4x8 HO Scale Small Model Railroad Layout | Gateway Central IV | 1997 Project Train Layout 1,799

18. Build a Small HO Scale Switching Layout | Track Plan & Parts List 1,749

19. Greater St. Louis Area Model Railroad and Train Layouts | Page 1 | A-B | Gateway NMRA 1,624

20. HO Scale Model Buildings and Structures on the Missouri History Museum Train Layout, Page 1 1,432

21. 2009 Train Show Model and Photo Contest | Gateway Division NMRA 1,428

22. Greater St. Louis Area Model Railroad and Train Layouts | Page 2 | C-J | Gateway NMRA 1,414

23. Bob Johnson Pseudo-Soo HO Scale Model Railroad Layout | Page 1 of 3 1,314

24. 2004 N Scale Model Railroad Layout | Gateway Central XI 1,292

25. Photos of Missouri History Museum Model Railroad Layout | Page 1 of 2 1,266

26. Gateway Central VIII (2001) Small HO Scale Model Railroad Layout | Article with photos and trackplan 1,188

27. Designing Model Railroad Operations | Quick Start Techniques and Examples 1,078

28. Phil Bonzon's HO scale Buffalo Creek and Gauley Railroad 1,006
29. DCC (Digital Command Control) Power Bus Wiring for Model Railroads 982
30. Bob Buschart's HO Scale Model Railroad Layout 980
(Plus 223 more web pages and thousands of photos)

RSS Feed: Feeds are a way for websites to distribute their content beyond just visitors using browsers. Feeds permit subscription to regular updates, delivered automatically via a web portal, newsreader, or even by e-mail. Want to know what's new on the GatewayNMRA.org website? Just go to our home page and enter your e-mail address in the "Subscribe to Website Updates" box. This is a double opt-in system; you will receive an e-mail from Google that you will need to confirm to complete your subscription. We currently have about 170 subscribers to the RSS feed.

There have been 430 clicks and 2,420 views to content from this Feed in December 2010, and 14,182 clicks and 41,955 views to content since the start (11/11/2008) of this Feed.

IX. Officers/Department Chairs for 2011:

Superintendent: Hank Kraichely
Assistant Superintendent: Bill Linson
Division Director: Phil Bonzon MMR
Paymaster: Dave Lyon
Clerk/Secretary: Don Ayres
Membership Chairman: Phil Bonzon MMR
Monthly E-mail Notice Manager: Jimmy Ables
AP Co- Chairmen: Don Taschner MMR and Phil Bonzon MMR
RPO Editor: Mike Thomas
Gateway Website Manager: Richard Schumacher
Gateway Rail Op Weekend Chairman: Phil Bonzon MMR
Contest Chairman: John Carty

X. Deaths:

Fortunately the Gateway Division has not had any members die in the past year.

Finally, the members of Gateway Division would like to acknowledge the fine work and support that Tim Stout has provided in his years of service as the Gateway Assistant Superintend. Also, I wish to thank the officers/department chairs for their help in preparation of this report.

Division Minutes

by Don Ayers

Gateway Division Meeting September 20, 2010

CLINIC – Contest judging of members' building the American Model Builders "Company House" structure kit as given out free to those who attended the May meeting. Kits were generously donated by American Model Builders President John Hitzeman, who did the judging. John gave a little history on how he came up with the idea for the house, which AMB has sold over 12,000 kits over the years. Basis for the contest was to build, decorate and detail the exterior of the structure. Thirteen members submitted finished kits. First prize went to Phil Bonzon, second prize went to Dick Wegner and third prize went to Gregor Moe. Congratulations to the winners but, more importantly, congratulations to the 13 members who participated in the contest. A job well done!

BUSINESS MEETING – The Superintendent called the business meeting to order at 8:00 PM. There were 32 members present, including new member Dave Bufka, and visiting member Doris Taschner, along with guests Vicki Siering and John Hitzeman. Dave is an HO scale modeler. An item of note, Don and Doris Taschner are celebrating their 60-year wedding anniversary.

Minutes of the August Meeting: Minutes were APPROVED with one correction. Approved minutes are published in our quarterly publication, the RPO.

Treasurer's Report: Dave reported there was nothing unusual this month. Most of the money that came in was from the sale of wheel sets. Under Expenditures, Miscellaneous, \$300.00 was for purchasing gift certificates to be used as prizes. There were no questions. Report APPROVED. Hank did ask Gary Gross to set up a meeting with Dave to perform the annual audit of Treasurer activities.

Merchandise Report: Tim reported he still has the 33-inch wheel sets left. The trucks are still on backorder. A request was made for 36-inch wheel sets, which we don't have. Hank said the minimum order is 100 packages to receive the discount price. Tim said we also have N scale standard gauges as well as On3 gauges.

RPO Report: Mike Thomas said what's due to him is Hank's column, a ballot with the names of officer candidates for the upcoming election

and a flier for the Fall Meet. Deadline is October 1st. Mike said he should be able to work on the program for the Fall Meet itself. He has a galley proof of the membership directory for those at the meeting to check spelling of names, correct addresses, telephone numbers and email addresses. Also, check if we have any deceased members listed. Hank strongly recommended everyone at the meeting look at the galley proof. Ron Gawedzinski mentioned that in processing the names of members signed up for the upcoming picnic there were some errors in telephone numbers, etc, and that he would get those changes to Mike.

Directors Report: Phil reported Richard Napper, Mid-Continent Region Membership Dispatcher, has resigned. There is no replacement yet for him in that position.

Achievement Program (AP) Report: Hank mentioned we now have two co-chairman for this position, Don Taschner and Phil Bonzon. Don awarded Gene Coffman the Golden Spike Award. The members in attendance gave Gene a round of applause. Don also said Phil and Rich Lake visited Gregor Moe's home layout and judged scenery and civil areas.

Old Business

Tabletop Display – Don Ayres was not present as he was out of town on a work assignment. Hank reported that the new display Don created and constructed was shown at the recent Narrow Gauge Convention. Hank said Don did an outstanding job. The display will be shown at the MVNScalers train show at the Kirkwood Community Center on Saturday, October 9, 10 AM – 5 PM, and Sunday, October 10, 11 AM – 4 PM. Phil said we need volunteers to man the booth. He passed around a sign up sheet.

New Member Recruitment Hobby Shop Display Posters – Phil mentioned different people had the assignment to bring the posters to a hobby shop and monitor if more were needed. He followed up with those people at the meeting to see if more posters were needed. He encouraged the persons to check the hobby shops on a timely basis and let him know next week what the status is.

New Division Shirts – Hank reported Don sent the new NMRA logo to the company that would embroider the shirts. Unfortunately they sent it back saying they can't read it. Hank sent the logo back to National and asked for it in a different format. Hopefully we'll be able to show you something next month.

Narrow Gauge Convention – Hank asked those who attended if they would make a

couple of comments. Richard Lake said if you didn't go you missed a really good event. First class model contest room, outstanding clinics and wonderful home layouts and a very large manufacturers display. Hank mentioned the Division had two of its members who won prizes. Phil won 1st place for his passenger car. Dave Roeder got 3rd place for his freight car. Members in attendance gave the prizewinners a round of applause. Hank said if you're interested in seeing photographs of the models there is a website to go to,

"30ngconvention.org/pdfofcontestwinners.pdf". Phil mentioned we were able to recruit a new member for Kentucky and one for Indiana but none for our Division.

Division Layout OP Weekend – Phil reported we had 37 people registered. We had to cancel a couple of sessions because we did not have enough people to operate the layouts. He sent out a survey to everybody who participated. He's received back 10 replies so far. All of them are very positive.

The consensus so far is let's make it a regular event twice a year on Friday and Saturday. Richard Lake said we should give a big thank you to the six members who opened their home layouts for this event and especially to Phil for organizing it. Members gave them a big round of applause. Phil said we're going to get some publicity out of it in a future article in the "Dispatcher," the OpSig magazine, and the NMRA magazine.

Hank reported next month the OpSig National Group will visit a number of our Division home layouts in October for two days. Fifty-two people are registered coming from all over the Midwest.

New Business

Outside Activities – Ron talked about the two upcoming joint activities that he has scheduled with the St. Louis Chapter National Railway Historical Society.

A joint group picnic will be held this coming Saturday, September 25th, at the Wabash, Frisco & Pacific Railway, from 11:00 AM until 4:00 PM. Lunch will be served at 12:30 PM. He had two sign up sheets for the picnic, one for attendance and one for volunteers.

A joint group tour of the Barriger National Railroad Library (on the UMMSL North campus) is scheduled for Saturday, October 23rd, from 1:00 PM to 4:00 PM. A sign up sheet was available to attend this event.

Members are invited to attend a special presentation on the "12th St. Tunnel: St. Louis' Other Railroad Station," given by Bill Heger, member St. Louis Chapter NRHS, on

Thursday, October 28th, 7:00 PM, at the St. Louis County Library, Cliff Cave Branch, 5430 Telegraph Rd, South St. Louis County. Light refreshments served. Program guides were made available.

The St. Louis Chapter NRHS is reproducing the Wabash Banner (Highland) Pattern Dinnerware as used in Wabash dining cars from 1947 – 1960's. Proceeds from the sale of this dinnerware will be used to cosmetically restore the Wabash #573, a 2-6-0 Mogul steam engine, located at the St. Louis Museum of Transportation. This was the last steam engine used by the Wabash Railroad. Order forms were made available.

Photographs of "Company House" Models for the RPO – Phil said he is going to photograph all the models for the RPO. Please put your name on a piece of paper with your model. Book Sale at the Barriger National Railroad Library – Hank mentioned he received an email from Greg Ames, the librarian, that 2,000 books are for sale today, tomorrow and Wednesday, 10:00 AM – 4:00 PM. Hank has asked Don Head to send a mass email notice to all members with the specific instructions. Next Month's Clinic – Tim said next month's clinic will be by Brian Post on DCC, a hands-on clinic, with demonstrating speed matching different locomotives. Brian will bring his locomotives.

Announcements

Tim reminded members about the Fall Meet on Saturday, November 13th. We're looking for clinicians.

Bill Birdsell said the Metro East Model RR Club, Glen Carbon, Illinois, is having an open house on Friday, October 1st, 5:00 PM to 8:00 PM, and Saturday, October 2nd, 10:00 AM to 3:00 PM.

Hank said we're looking for a candidate for Vice President (Asst. Super.), in 2011, Tim's job. See Hank if you are interested.

Rich Velten said the Kirkwood Railroad Association is having an open house on Saturday, December 11th, from 12 noon to 5:00 PM, corner of Lockwood and Sappington, Hough Community Learning Center.

Richard Lake commented about a hot air balloon from the race landing on Waterman about 200 ft. from their home on Saturday afternoon Division layout OP session.

Dick Wegner said the Division owes John Hitzeman and his Company (AMB) a lot of thanks for donating the kits for the contest tonight and for his taking his time to be here to judge the entries. The members gave John a large round of applause.

50/50 -- \$35.00 was collected, and Dale Talbott won the drawing and took home \$18.00, with \$17.00 going to the Treasurer. **Adjournment:** Richard Lake made a motion to adjourn the business meeting at 9:05 PM, and the motion was seconded by Dave Lyon and PASSED.

Respectfully Submitted,
Ron Gawedzinski, Acting Clerk

Meeting Minutes for October 18, 2010

CLINIC – Brian Post was to have presented a clinic on speed matching different brands of decoders/locomotives. Word was that he was running late, so Hank started the business meeting. After the meeting, it was announced that Brian was unable to get away from work in time. We'll be looking for Brian to reprise his effort early next year.

BUSINESS MEETING – The Superintendent called the business meeting to order at 7:00 PM. There were 17 members present, including 2 new members, Ali Shahriari and Joseph Kamm. Ali is an N scaler, and is working on his layout in an 11 x 14 room. Joe is improving his space for a future layout.

Minutes of the September Meeting: There were no comments on the September minutes. A motion was made by Phil to approve the Minutes; seconded by John Carty. PASSED. (Motions are not necessary; only approval is required.) Approved minutes are published in our quarterly publication, the RPO.

Treasurers Report: Jim Anderson delivered the report for the ailing Mr. Lyon. APPROVED as submitted.

Merchandise Report: The 10 sets of trucks from Intermountain were received and available for purchase by members. Tim also has wheelsets available and continues to push the standards gauges we have in various scales.

RPO Report: Mike Thomas was not present. No Report.

Directors Report: Phil is still trying to get National and Regional to update their monthly member reports more accurately. Phil is also trying to get National to send us the Division portion of each member's annual dues. No progress.

Activity Report: Phil summarized the recent operations sessions in members homes and thanked everyone for participation – especially the hosts!!! Members have requested that this be a recurring event. He's thinking twice a year could work.

Ron summarized the annual picnic and thanked everyone involved.

Ron reminded everyone to visit the Barriger library with him this coming Saturday.

Ron is also was coordinating members to see the feature film "Runaway".

Achievement Program (AP) Report Don and Phil presented certificates to Gregor Moe: 3 for track and one for scenery. This completes his submissions and Phil announced that he would be getting his AP for both master builder Scenery, and master builder Civil Engineer.

Monthly Meeting Clinician Report Hank reminded everyone that next month's meeting will be the Holiday Party! No business meeting! Bill Linson will show his vacation photo's – which included lots of rail-fanning! Tim reported that the December clinic will have members try a switching challenge on our switching layout. Come and complete the challenge in the fewest moves!

Old Business

The annual Officers Planning Meeting was held in January. The following few items remain open:

Recruitment – No report this month. OPEN. Tabletop Display – The updated display was used for the first time at the Narrow Gauge Convention. CLOSED.

Logo Shirts - Don is having trouble getting the vendor who promised the best pricing to us to produce some sample art for the membership to vote on. John Carty recommended a couple of vendors that he was aware of who might want our business. OPEN.

New Business

Following the contest in September where membership all built the same structure kit for judging, a suggestion was made to set aside previous winners in to a separate "expert" group, so that others may win. Following much discussion amongst the officers, it was decided that there would be an "expert" class, and an "all other" class. This will open up more opportunities for winning prizes. No modeler will be excluded from competing in the annual model contest held at regular meetings. The model contest at Fall Meet will continue to operate using NMRA rules as before. (We will start excluding models that have previously won another NMRA contest. This has always been an NMRA rule but had been overlooked in the past. This discussion has refreshed our memories.) Dave Roeder wanted to make sure it was known that no one surveyed thought it was fair to limit entries for the People's Choice Award at the Division's

annual model contest at the Fall Meet. While there was lively discussion over these two contest related issues, no motions were made. CLOSED.

Announcements: After the above exchange, there was more discussion on contests in general: Tim talked about how Don Taschner encouraged him to begin entering contests. Referencing the Fall Meet, John Carty encouraged members not to flood a category with multiple models, but instead to bring their best model for a particular category. The Clerk thanked Ron Gawedzinski for performing Clerk duties in September while the Clerk was out of town.

Phil reminded those who took responsibility for keeping membership applications available at their local hobby shops to continue checking on supplies.

50/50 – Twenty dollars was collected, and Phil won the drawing and took home \$10. The treasury was likewise enriched by \$10. Tim won the Mark Twain Hobbies gift card. Obviously, both of these guys should be placed in the "expert" group for next year's drawings!!

Adjournment: Dick Wenger made a motion to adjourn the business meeting at 8:02 PM. Motion PASSED.

Respectfully Submitted,
Don Ayres, Gateway Division Clerk

Meeting Minutes for December 20, 2010

CLINIC – Tonight, we had a friendly competition to see who could complete a switching challenge on our HO scale switching layout that we use at shows. The challenge was to spot five boxcars at the correct industry in 8 minutes or less. Along with the fun, there were some injuries along the way (in the frenzy to get done fast!), and even one death of a fisherman on the ground was reported as a boxcar fell off of the stone viaduct. But, in the end, the team of Jimmy Ables and Bill Linson emerged as winners with all cars spotted correctly and a time of 7:35, and no reportable injuries. These gentlemen received a Mark Twain Hobbies gift card for their effort.

BUSINESS MEETING – The Superintendent called the business meeting to order at 7:08 PM. There were 19 members present, and one guest: Rob Kurtz.

Minutes of the October Meeting: Minutes were APPROVED with one spelling correction. Approved minutes are published in our quarterly publication, the RPO.

Treasurers Report: Dave summarized his report. The revenue from the Fall Meet showed up this month, so we plussed up! Dave fielded a few questions. The report was then APPROVED as read.

Merchandise Report: Tim reported that there are 4 sets of trucks left, and 47 packs of the 33" wheelsets available. He also continues to push the standards gauges – especially N scale. He said we may order 36" wheelsets next time.

RPO Report: Mike Thomas was not present. No Report.

Directors Report: Phil mentioned that he will be attending the Board of Directors meeting on 22 January, in Shawnee, Kansas. Also, we have added a few new members.

Activity Report: Ron was not present. No Report.

Achievement Program (AP) Report: Phil is still waiting for the certificates to be delivered for Gregor Moe. Don Taschner has the Merit Awards earned at the Fall Meet.

Monthly Meeting Clinician Report: January and February will feature 2 Master Model Railroaders each month to teach us aspects of the hobby. We will also look for Brian Post to come back and do his speed matching clinic. Hank asked the group for other ideas for clinics that they would like to see next year.

Old Business

The annual Officers Planning Meeting was held in January. The following few items remain open:

Recruitment – No report this month. OPEN.
Logo Shirts - Don showed the members present the new proposed logo. There was lots of discussion about this logo, and a few new ideas floated. The vendor that created the logo put a silver(gray?) border around National's logo. Ultimately, membership voted for this logo, but wanted to give National the final say-so on the variation. A shirt was also agreed to from the catalog. The vendor will provide a red, short sleeve, polo shirt with one pocket and the new GD embroidered logo for \$32. Embroidering a name on the shirt will be \$5 extra. OPEN.

New Business

Hank announced the results of the officer elections for 2011, as tallied by Mike Thomas. Hank, Dave, and Don will continue in their current roles in 2011, while Bill Linson will become our new Assistant Superintendent. Tim agreed to continue to handle the merchandise. Don made a motion to destroy the ballots for the 2011 officer elections. Ken Thompson SECONDED. Motion PASSED.
Announcements

Phil is looking for volunteers to man the NMRA table at The Great Train Expo, St. Charles Convention Center, St. Charles, Missouri, on 29 and 30 January. As usual, we need at least 2 volunteers for each of the 4 shifts.

Phil had a copy of *opsig* magazine which had a nice write-up on our recent ops weekend.

50/50 – Twenty six dollars was collected; Jim Anderson won and took home \$13. The treasury was likewise enriched by \$13. Phil won the Mark Twain Hobbies gift card.

Adjournment – Rich Lake made a motion to adjourn the business meeting at 7:56 PM.

Dick Wenger SECONDED. Motion PASSED.

Respectfully Submitted,
Don Ayres, Gateway Division Clerk

Division Officers

Superintendent

Hank Kraichely

Assistant Superintendent

Bill Linson

Clerk (Secretary)

Don Ayres

Paymaster (Treasurer)

Dave Lyon

Division Director

Phil Bonzon, MMR